

EMERGENCY ESCAPE

*Guidelines for planning
emergency escape
windows and window wells.*



Kandiyohi County Egress Window Handout

Thousands of fires occur in residences each year. Many of these fires occur at night when the occupants are asleep. Severe injuries or death can be the result of these fires if the occupants are asleep and unaware the fire is in progress. Death usually results from asphyxiation long before the fire reaches the occupants.

In order to prevent the tragic loss of life the Minnesota State Building Code requires smoke alarms be installed in dwellings to alert the occupants of a fire. The code also requires that sleeping rooms and basements in dwelling units have windows or doors, which may be used for emergency escape or rescue if the fire has blocked the normal escape routes in the home.

Basements pose a special danger since they usually have only one stairway to act as a means of escape. This stairway can easily be blocked by fire making escape from the basement impossible. For this reason the Minnesota State Building Code requires that in basement spaces at least one emergency egress window or door is provided.

The size of windows and doors required in the code are based on extensive research to determine the proper relationship of height and width of window openings to adequately serve for both rescue and escape.

People come in all sizes and windows come in all shapes. A fireman attempting a rescue will likely be wearing full rescue gear, which may include breathing apparatus.

The size determined as a minimum for escape and rescue is 5.7 square feet of clear openable area or 5.0 square feet for grade floor openings (see the 2006 IRC for detailed information). Since windows come in all shapes and sizes a minimum width dimension was needed to accommodate tall window shapes and a minimum height dimension for wide window shapes. Studies have determined the minimum net clear width needed is 20 inches and a minimum net clear height of 24 inches. These dimensions are part of the code requirements and assure the window or door will provide safe exit or rescue.

Emergency escape windows and doors must be located on the exterior of the building and open directly to a yard, street or alley so that the occupants may escape or be rescued directly from the room to the outside without having to travel through the building itself.

In a fire, time is critical to survival. You may not have time to instruct family members and guests on proper window operation or to perform complex operations to get the window open. The code requires windows and doors used for emergency escape and rescue to be readily open able without any special knowledge or effort. The intent is that windows be of the common double-hung, horizontal sliding or casement type. Your local building inspector will need to be consulted to assist you in evaluating special types of windows.

Special windows need to be evaluated based on the difficulty and knowledge needed to operate or remove the windows.

ESCAPE Continued

EMERGENCY ESCAPE AND RESCUE OPENINGS

Basements and every sleeping room shall have at least one open able emergency escape and rescue window or exterior door opening for emergency escape and rescue. Where openings are provided as a means of escape and rescue, they shall have a sill height of not more than 44 inches above the finished floor. Where a door opening having a threshold below the adjacent ground elevation serves as an escape and rescue opening and is provided with a bulkhead enclosure, it shall comply with section R310.3. The net clear opening dimensions required by this section shall be obtained by the normal operation of the window or door opening from the inside. Escape and rescue window openings with a finished sill height below the adjacent ground elevation shall be provided with a window well in accordance with section R310.2. A minimum ceiling height of 36 inches shall be maintained above the exterior grade from the exterior wall to a public way. (Windows under a deck)

Exception: Basements used to house mechanical equipment only and do not exceed 200 square feet of floor area.

Minimum opening area. All emergency escape and rescue openings shall have a minimum net clear opening of 5.7 square feet. **Exception:** Grade floor openings shall have a minimum net clear opening of 5.0 square feet if the sill height does not exceed 44 inches above finish grade.

Minimum opening height. The minimum net clear opening height shall be 24 inches.

Minimum opening width. Minimum net clear opening width shall be 20 inches.

Operational constraints. Emergency escape and rescue openings shall be operational from the inside of the room without the use of keys, tools or special knowledge.

Installations after March 31, 2003 Exception: Grade floor openings shall have a minimum net clear opening of 5.0 square feet. A grade floor opening is a window or other opening located such that the sill height of the opening is not more than 44 inches above or below the finished ground level adjacent to the opening.

Replacement window. Replacement windows installed in buildings meeting the scope of the International Residential Code shall be exempt from the requirements of section R310.1.1, R310.2.2, and R310.1.3 if the replacement window meets the following conditions:

1. The replacement window is the manufacture's largest standard size window that will fit within the existing window frame or existing rough opening. The replacement window shall be permitted to be the same operation style as the existing window or a style that provides for a greater window opening area than the existing window.
2. The rooms or areas are not used for any Minnesota State licensed purpose requiring an egress window.
3. The window is not required to be replaced pursuant to a locally adopted rental housing, or property maintenance code, or rental licensing code.

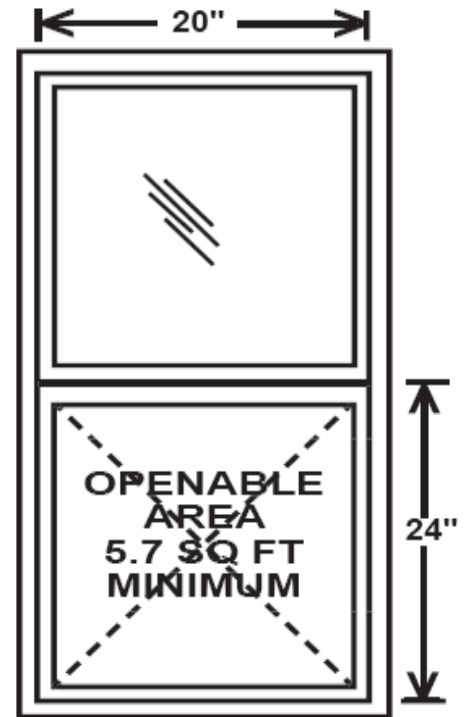

ESCAPE Continued

Window wells. Window wells required for emergency escape and rescue shall have horizontal dimensions that allow the door or window of the emergency escape and rescue openings to be fully opened. The horizontal dimensions of the window well shall provide a minimum net clear area of 9 square feet with a minimum horizontal projection and width of 36 inches. **Exception:** The ladder or steps required by section R310.2.1 shall be permitted to encroach a maximum of 6 inches into the required dimensions of the window well.

Bulkhead enclosures. Bulkhead enclosures shall provide direct access to the basement. The bulkhead enclosure with the door panels in the fully open position shall provide the minimum net clear opening required by section R310.1.1. Bars, grills, covers, screens, or similar devices are permitted to be placed over emergency escape and rescue openings, bulkhead enclosures, or window wells that serve such openings, provided the minimum net clear opening size complies with sections R310.1.1 thru R310.1.3, and such devices shall be releasable from the inside without the use of a key, tool, or force greater than that which is required for normal operation of the escape and rescue opening.

Ladders and steps. Window wells with a vertical depth greater than 44 inches below the adjacent ground level shall be equipped with a permanently affixed ladder or steps useable with the window in the fully open position. Ladders or steps required by this section shall not be required to comply with section R311.5 and R311.6. Ladders or rungs shall have an inside width of at least 12 inches, shall project at least 3 inches from the wall, and shall be spaced not more than 18 inches on center for the full height of the window well.

Guards. Although the code does not specify requirements for guards around window wells to keep persons from falling into them, falls can and do occur. Because of the variation in size, location, and depth of window wells and since a guard could present an impediment to escape or rescue, the code is silent. The potential for falls into a window well should be evaluated by the homeowner and suitable guards or visual barriers provided based on the location, depth, and size of the well. Barriers, guards, or covers installed to prevent falls must be placed in such a way that does not impede use of the window well for escape and rescue. If covers are used, the effects of snow on the ability to open or remove the in an emergency must also be evaluated. The ever-increasing concern for security, particularly in residential buildings has created a fairly large demand for security devices such as grills, bars, and steel shutters. Unless properly designed and constructed, these security devices over emergency windows can completely defeat the purpose of the emergency escape and rescue window. The code makes provisions for use of security devices, provided the release mechanism has been approved by the Building Official and it is operable from the inside without the use of a key or special knowledge.

Fire deaths have been attributed to the inability of the individual to escape from the building because the security bars prevented emergency escape. Security devices should only be installed where absolutely necessary and only with a permit after an evaluation by your local Building Official.

